

A-A剖视图

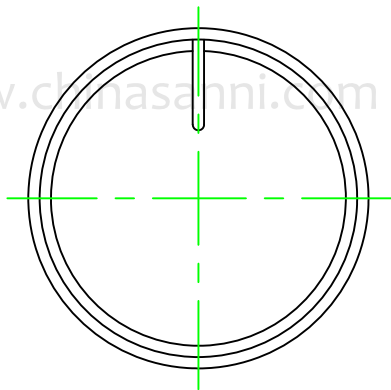

3D图

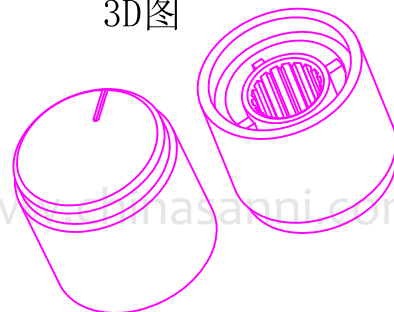

技术要求:

- 1: 零件不能有压伤、缺料、多料、混料、划伤、变形等不良现象。
- 2: 所有披锋需小于0.05mm。
- 3: 塑胶旋钮组装后紧固力大于5kgf.cm
不能出现打滑转动, 不能有芯子脱出现象。
- 5: 喷砂+氧化亮黑色, 颜色一致。

Material No. 铝+ABS				Dispose: 喷砂+氧化亮黑色		S:	D:	V:	M:
△				TOL UNLESS OTHERWISE STATED		DESIGNED	CHECKED		
△				BASIC DIMENSION	TOLERANCE	SANNI ELECTRONIC TECHNOLOGY			
△				Less than 1.00	±0.05				
△				1.00-less than 10.0	±0.1	DRAWING No.		Model No.	XN-202-KQ
△				10.0-less than 50.0	±0.15	UNIT mm	Edition A1.0	Document No.	XN-202 旋钮
SYMB	REVISION	DATE	APPROVED	ANGLE	±0.5°	SCALE 3:1	2024-07/18		